

RECOMMENDED P.C.B. LAYOUT

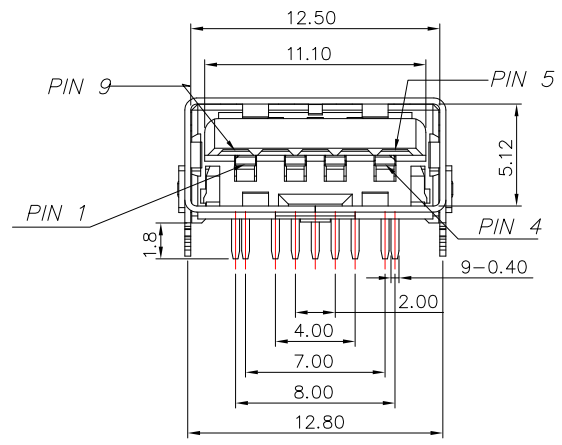

SUA-110H25-31x-S407

- 鍍層厚度:
- Blank : 1u"
  - 2 : 15u"
  - 3 : 30u"

PIN ASSIGNMENT:

Pin No.	1	2	3	4	5	6	7	8	9
Signal Name	VBUS	D-	D+	GND	SSRX-	SSRX+	GND_DRAIN	SSTX-	SS+
Remark	USB2 Contact Pin			USB3 Contact Pin					

SPECIFICATIONS

- Electrical:**
- Rating: 30 V AC, 1.8 A for VBUS and GND  
0.25A for other
  - Dielectric Withstand Voltage: 100V AC
  - Contact Resistance: 30 mΩ Max
  - Insulation Resistance: 100 MΩ Min
- Mechanical:**
- Connector Mate and Unmate Force
    - Mate force: 35N Max
    - Unmate force: 10 N Min
- Material:**
- Housing: PA9T,Black
  - Contact: C7025
  - Shell: SUS
- Finish:**
- Contact: Plated Gold in Mating Area ;  
Tin Plated on Solder Balls ;  
Nickel under plated overall
  - Shell: Nickel under Plated surface layer



TOLERANCE UNLESS OTHERWISE STATED:

- Up to 5 ±0.2
- Above 5 ~ 15 ±0.3
- Above 15 ~ 30 ±0.4
- Above 30 ~ 50 ±0.5
- Angle ±0.3°

3RD. ANGEL'S



UNITS MM

DRAWN BY:	DATE	MAT'L	TITLE	CONNECTOR
Jack Lu	01/17/22	FINISH	MODLE	USB 3.1 AF DIP TYPE CH3.4mm
CHECKED BY:	DATE	SCALE	DWG NO.	SUA-110H25-31x-S407
Jacky Chen	01/17/22	SHEET NO.	PART NO.	SUA-110H25-31x-S407
APPROVED BY:	DATE	SIZE	VER	R
Tony Kao	01/17/22	A4		

ITEM NO.	DESCRIPTION	DRAWN	DATE